

## KS FLANGE BALL VALVE

15A-300A Q41F-0.98MPa

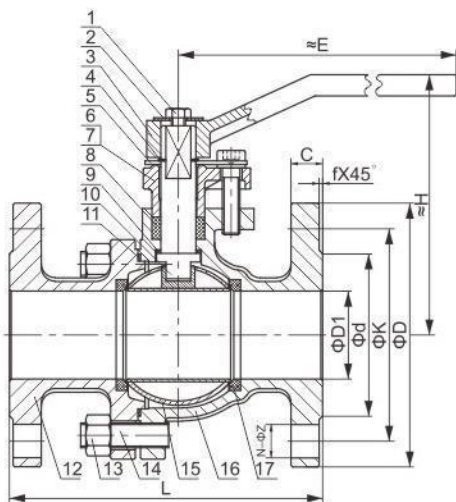

### 技术要求 Applicable Standards

1. 设计标准 Design Rating: KS B2308 ;
2. 结构长度 Face to Face: KS B2308;
3. 法兰标准 Flanged Ends: KS B1511;
4. 检查和试验 Inspection & Testing: KS B2308.

### 主要零部件材料 Main Parts and Materials

No.	零件名称 PAPT NAME	材质 MATERIAL	
1	螺栓 Screw	SM25C	STS304
2	垫片 Washer	SS400	STS304
3	手柄 Handle	SCPH2	
4	挡圈 Retaining ring	SPS3	STS304
5	限位块 Orientation patch	SS400	STS304
6	螺钉 Screw	SM25C	STS304
7	填料压盖 Gland	SCPH2	SSC13
8	填料 Packing	PTFE	
9	止推垫 Thrust Gasket	PTFE	

No.	零件名称 PAPT NAME	材质 MATERIAL	
10	阀杆 Stem	STS304	STS304/316
11	密封垫 Gasket	PTFE	
12	阀盖 Bonnet	SCPH2	SSC13/SSC14
13	螺母 Nut	SM35C	STS304
14	螺柱 Stud	SM45C	STS304
15	球体 Ball	STS304	STS304/316
16	阀体 Body	SCPH2	SSC13/SSC14
17	阀座 Seat	PTFE	
18			

### 主要外形尺寸和连接尺寸 Main External and Connecting Dimensions

NPS	D1	d	K	D	C	f	N-ΦZ	L	H	E
15A	15	51	70	95	12	1	4-15	108	79	125
20A	20	56	75	100	14	1	4-15	117	82	125
25A	25	67	90	125	14	1	4-19	127	102	155
32A	32	76	100	135	16	2	4-19	140	106	155
40A	40	81	105	140	16	2	4-19	165	128	240
50A	50	96	120	155	16	2	4-19	178	135	240
65A	65	116	140	175	18	2	4-19	190	145	280
80A	78	126	150	185	18	2	8-19	203	160	320
100A	98	151	175	210	18	2	8-19	229	180	320
125A	123	182	210	250	20	2	8-23	356	252	530
150A	148	212	240	280	22	2	8-23	394	285	630
200A	198	262	290	330	22	2	12-23	457	385	800
250A	248	324	355	400	24	2	12-25	533	485	涡轮 Turbine
300A	298	368	400	445	24	3	16-25	610	545	